

LOC	DIST	P	F	ZONE	LTR	REVISIONS	DATE	APPD
AF	50					DESCRIPTION		
					K	REVISED PER 0710-0156-95	18/APR/95	R6/NN

- 1 CONTINUOUS STRIP ON REELS WITH TERMINALS LOCATED ON 5.08 [.200] CENTERS.
- ② SLOT ACCEPTS A 0.25-0.32 mm DIA [#30-#28] AWG COPPER MAGNET WIRE ONLY (2 WIRES MAX).
- ③ WIRE BARREL ACCEPTS 0.12-0.40 mm² [#26-#22] AWG LEAD WIRE.
- ④ IDENTIFICATION NUMBER FOR MAGNET WIRE RANGE.

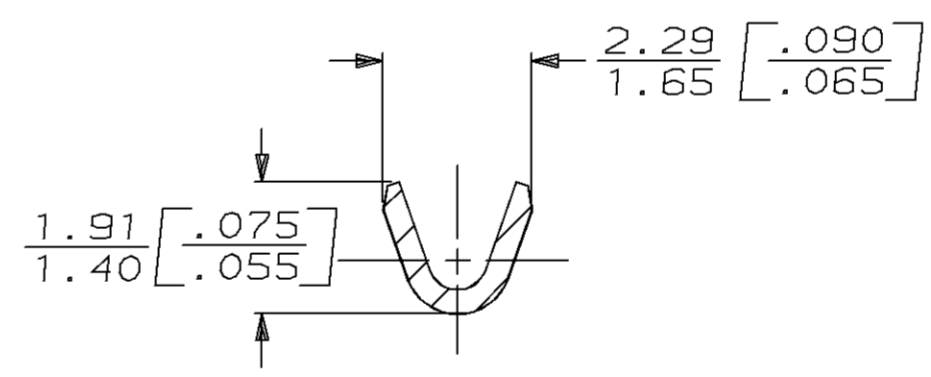
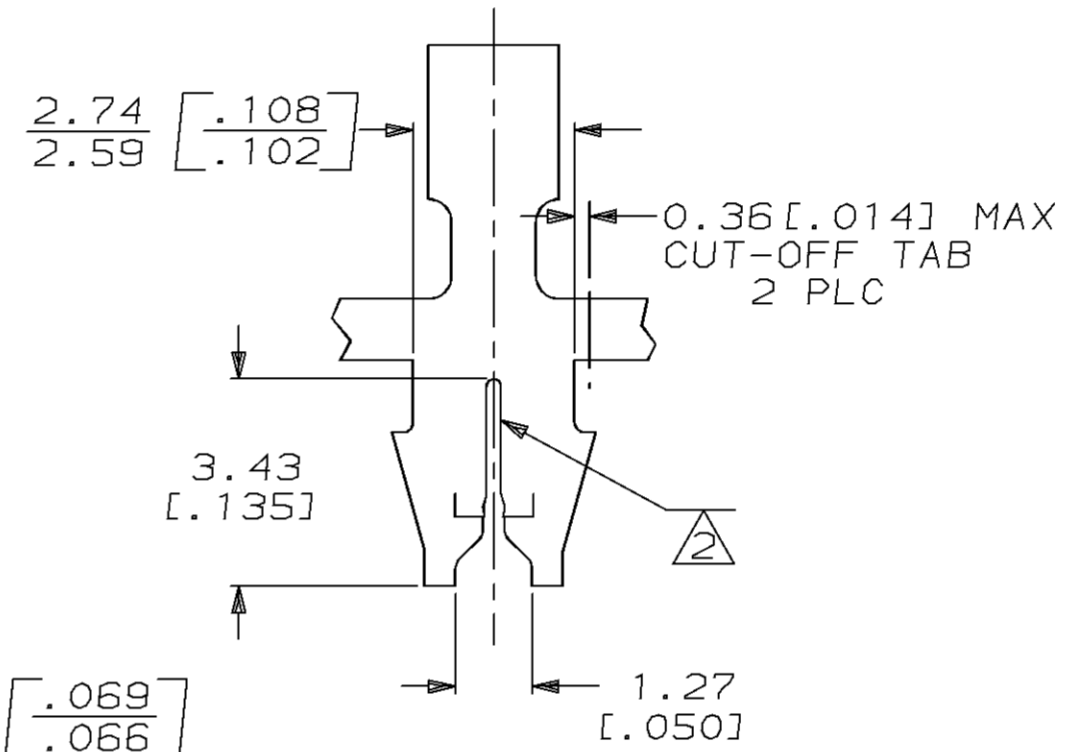
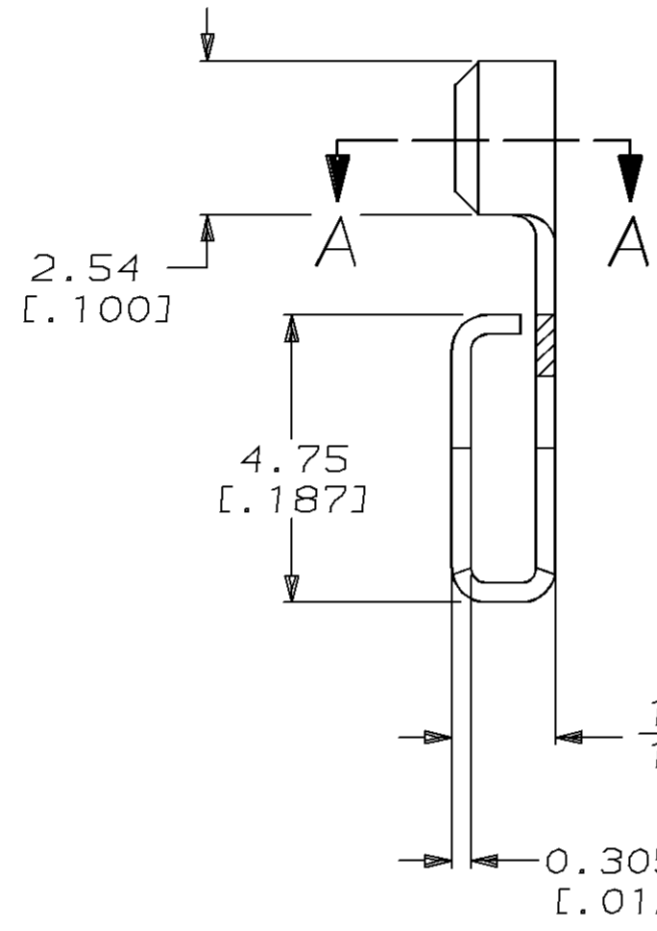
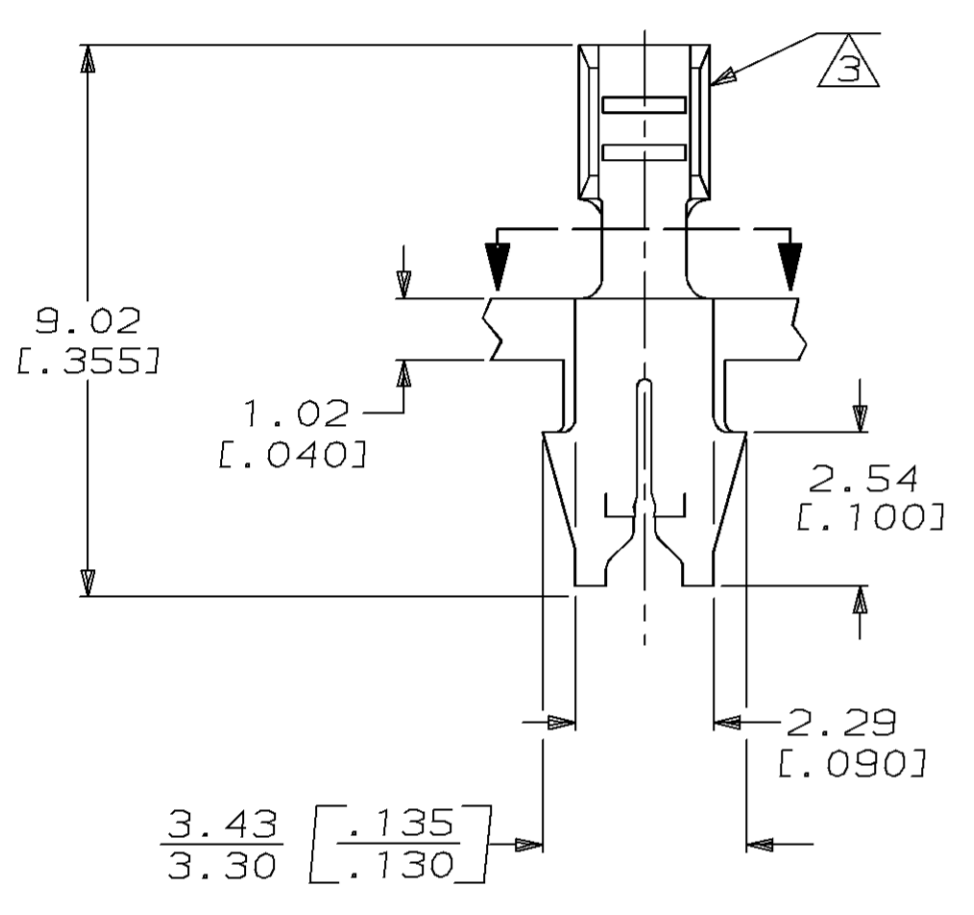
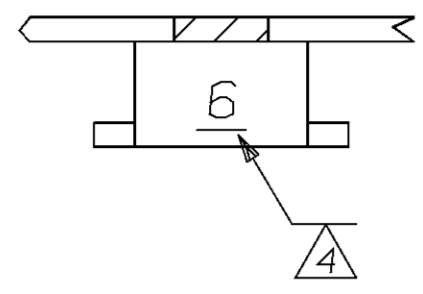

SECTION A-A
ROTATED 90° CW

3.56 [.140]	F	1.40 [.055]	0.97 [.038]	0.35 [.014]
			0.89 [.035]	0.20 [.008]
			0.86 [.034]	0.14 [.005]
STRIP LENGTH ±.015	TYPE	WIDTH	±0.051 [.002] HEIGHT	WIRE
WIRE BARREL CRIMP				



REVERSE REEL OF 62608-1	0.00381 [.000150] MIN THK PER MIL-T-10727	62608-3
-	0.00381 [.000150] MIN THK PER MIL-T-10727	62608-1
REELING	FINISH	PART NO
DO NOT SCALE PRINT. UNLESS SPECIFIED DIMENSIONS IN mm [INCHES] TOLERANCES ON : 2 PLC DEC ± - 3 PLC DEC ± 0.38 [.015] ANGLES ± -	DR 8/3/89 DK SCHRUM CHK 8/16/89 MS FEHER APPD 8/16/89 NE NEFF APPD 8/17/89 TL SHUTTER PRODUCT SPEC -	AMP AMP INCORPORATED Harrisburg, Pa. 17105
MATERIAL #4 HARD BRASS	FINISH SEE TABLE	NAME TERMINAL, F CRIMP, MAG-MATE™
	APPLICATION SPEC 114-2069	SIZE C CAGE CODE 00779 DRAWING NO 62608
	WEIGHT -	SCALE 8:1 SHEET 1 OF 1